



Project: \_\_\_\_\_ Item #: \_\_\_\_\_ Config #: \_\_\_\_\_

# Evo® EVent® 48E - Electric Cooktop in Ventless Recirculating Ventilation System

**Model #: 10-0148-EVT-CE**Model 10-0148-EVT-CE  
w/ 36" Casters Shown

## DESCRIPTION

The Evo EVent® 48E is an electrically controlled 1219mm x 610mm (48" x 24") rectangular steel cook top in an integrated ventless recirculating ventilation unit. Evo EEvents four combined heaters heat a static cooking zone with variable temperatures ranging from 38°C to 288°C (100°F to 550°F). A high velocity CFM ventless system provides full containment and capture from the intake aperture located on the chef-side adjacent the cooking surface, and a discharge duct on the chef-side returns clean filtered air. The duct system is fully welded stainless steel and utilizes a 4-stage filtration system including a washable stainless steel grease baffle filter, mesh particulate filter, electrostatic precipitator, and a replaceable activated charcoal filter. Factory installed fire suppression system with dry contact fire alarm micro switch and cross-pattern nozzles provide a continuous zone of fire protection.

## SPECIFICATIONS

**FILTRATION** - Completely self-contained 4-stage filtration process reduces grease emissions below that are allowed in NFPA 96 and ANSI UL710B using the EPA 202 test method. The self-contained 4-stage filtration system includes a washable stainless steel grease baffle filter, mesh particulate filter, electrostatic precipitator (ESP) and replaceable activated charcoal filter. All filters are easily removable with the included 8 mm hex key. Airflow sensors continually monitor airflow and grease removal while an interlock system will not allow unit to operate if filters are missing, clogged or in the event of a fire.

**FIRE PROTECTION** - Factory installed Buckeye® Kitchen Mister system includes BFR-5 tank, 2 - nitrogen cartridges, SRM control head, piping, flex cable, fusible link, nozzles and manual pull station. Manual pull is located on the chef side (front) of the unit. BFR-5 tank comes pre-filled (charged) with fire suppression chemical. Fire protection system meets NFPA 96 Chapter 13 and was tested to UL300 standards.

**Fire protection system must be armed and certified by Buckeye® Authorized distributor after installation and before first use (operators responsibility).**

**EXHAUST AND AIR FLOW** - Exhaust air is horizontal discharge. A minimum of 0.033 cubic meter (m³/s) of fresh air per minute is required both in and out of cooking area to ensure the dilution of cooking aromas. Dedicated Make-up Air unit is not required. Please consult your HVAC contractor.

**COOKING APPLIANCE** - The 48E unit includes a 1219mm x 610mm (48" x 24") flat rectangular steel cook surface with Evo® patented intelligent heating technology that provides a 610mm x 432mm heated cooking area. Each unit also includes a resistive touchscreen display that provides feedback on the operation of the unit.

## STANDARD FEATURES

- 1219mm x 610mm (48" x 24") flat rectangular steel cook surface
- Variable temperatures 38°C to 288°C (100°F to 550°F)
- Completely self-contained, 4-stage filtration system
- Resistive interactive touchscreen display that provides instant status of filters, grease drawers and control of temperature presets
- Stainless steel and aluminum construction for durability, strength and ease of cleaning
- Can be factory configured for 914mm (36") or 864mm (34") overall counter height
- Large removable grease collection tray
- Self-contained filtration process reduces emissions below that allowed in NFPA 96 and ANSI UL710B using the EPA 202 test method
- Pre-engineered factory installed fire protection system
- Fire protection system includes a dry contact micro switch for connection to a central fire alarm system (operators responsibility)
- Low noise with only 70 dBA average
- Evo EEvents are semi-mobile, making them easy to roll out for housekeeping and maintenance
- Chef-side accessible washable stainless steel grease baffle filter, mesh particulate filter and electrostatic precipitator (ESP) and replaceable activated charcoal filter
- Charcoal filter recommended replacement interval - 2 weeks
- Available in 220-240V, 50Hz, 1-phase or 380-415V, 50Hz, 3-phase (Customer provided cord and plug)
- Units ship with one complete set of 4 filters, grill surface cleaning kit, 2 stainless steel spatulas, grill scraper, and owner's manual
- Limited one-year parts and labor warranty

## AVAILABLE PARTS

- 10-0150-EVT-34 864mm (34") Caster Kit - ADA Compliant
- 10-0150-EVT-36 914mm (36") Caster Kit - Standard
- 10-0150-EVT-FMS Stainless Steel Surround
- 13-0200-EVT Electrostatic Precipitator (ESP)
- 13-0210-EVT Stainless Steel Grease Baffle Filter
- 13-0220-EVT Aluminum Mesh Pre-Filter
- 13-0230-EVT Replaceable Charcoal Filter
- 20-EVT-1200 Recommended Spare Parts Kit

## CERTIFICATIONS



Evo America, LLC 20360 SW Avery Ct., Tualatin, OR 97062

Ph 503-626-1802 • Fax 503-213-5869 • [evoamerica.com](http://evoamerica.com) • [sales@evoamerica.com](mailto:sales@evoamerica.com)

Evo is protected under U.S. Patents 9,897,328, 9,869,474, 10,139,113, 9,903,595, 10,842,540, 7,825,353 and U.S. Patents Pending.

NOTE: Due to ongoing product improvement, specifications are subject to change without notice and are not intended for installation purposes.

© Evo America, LLC 2021  
All Rights Reserved



# Evo® EVent® 48E - Electric Cooktop in Ventless Recirculating Ventilation System

Model #: 10-0148-EVT-CE

NOTE: Specifications are subject to change without notice.

ENVIRONMENTAL SPECIAL NOTICE: The ventilation system is designed to eliminate grease laden vapor & smoke and reduce odor but not eliminate odors. Air exchange at the installation site must comply with requirements of the local jurisdictional authority. To ensure dilution of odor buildup, minimum recommendation is 0.033 and 0.066 cubic meter (m³/s) of fresh air per minute both in and out of the cooking area.

MINIMUM CLEARANCE FROM UNIT TO NEAREST COMBUSTIBLE SURFACE (UNIT MUST BE SERVICEABLE FROM ALL SIDES)				
	Back (Guest)	Side	Front (Chef)	Top (Minimum Ceiling)
(mm)	(0)	(0)	(914) recommended (610) minimum	(2438) minimum ceiling height A.F.F (Above Finish Floor)
Inches	0"	0"	36" recommended 24" minimum	96" minimum ceiling height A.F.F (Above Finish Floor)

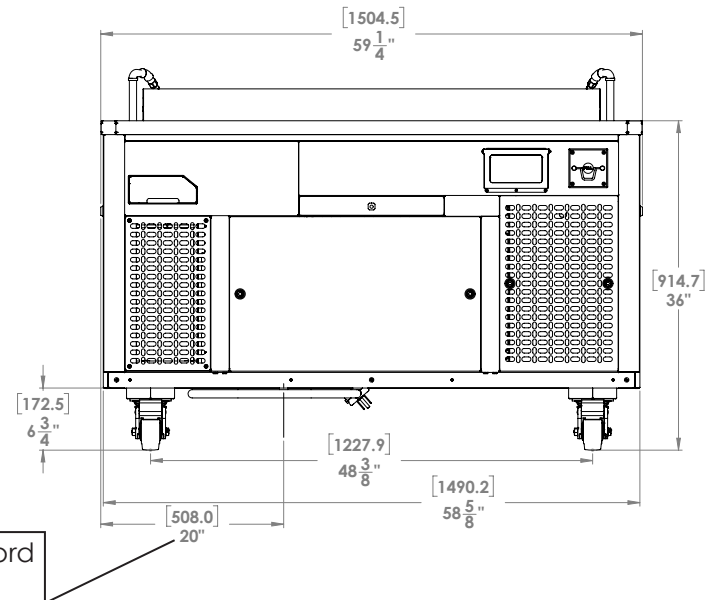
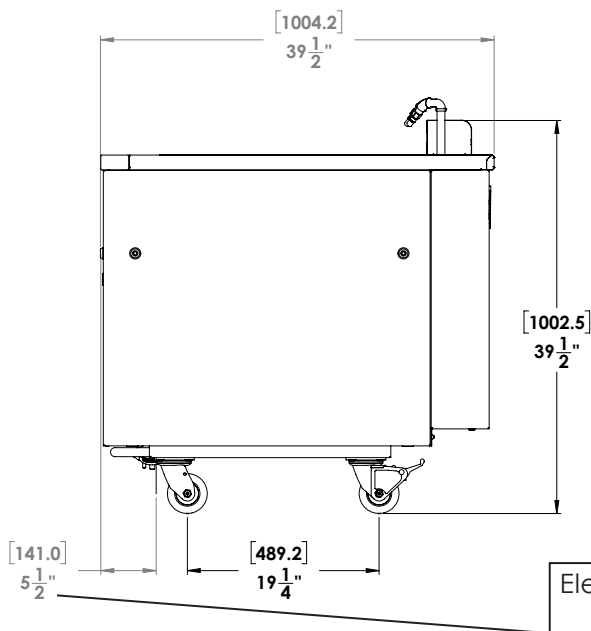
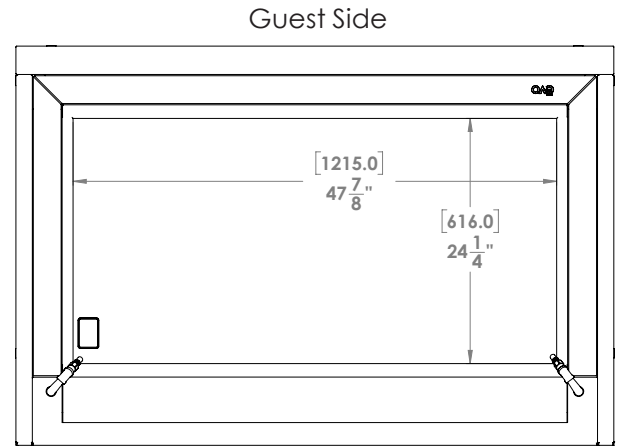
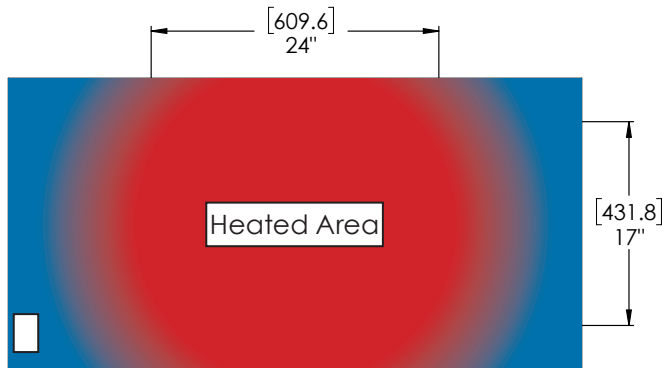

Model	Cooking Surface	Chassis Dimensions			Voltage & Phase	kW & AMP Draw	Max Breaker	Plug Type	Weight (Ship)
		H	W	D					
10-0148-EVT-CE	7442 cm² (1152 Inches²)	914mm or 864mm (36" or 34")	1504mm (59.25")	1004mm (39.5")	220 - 240V, 1 Ø 50Hz or 380 - 415V, 3 Ø 50Hz	6.82 - 7.44 kW 26 AMPS, 1 Ø or 6.82 - 7.44 kW 13 AMPS, 3 Ø	32 AMP (Dedicated)	Customer Provided Cord and Plug	388 kg 857 lbs (560 kg) (1235 lbs)

Evo America, LLC 20360 SW Avery Ct., Tualatin, OR 97062

Ph 503-626-1802 • Fax 503-213-5869 • [evoamerica.com](http://evoamerica.com) • [sales@evoamerica.com](mailto:sales@evoamerica.com)

Evo is protected under U.S. Patents 9,897,328, 9,869,474, 10,139,113, 9,903,595, 10,842,540, 7,825,353 and U.S. Patents Pending.

Due to periodic changes in design, procedures, methods, regulations and policies, the specifications contained in this sheet are subject to change without notice. While Evo exercises good faith efforts to provide accurate information, we are not responsible for errors or omissions in information provided or conclusions reached as a result of using the specifications. By using the information provided, the user assumes all risks in connection with such use.

© Evo America, LLC 2021  
All Rights Reserved



## > DESIGN & INSTALLATION CONSIDERATIONS

### Positioning the Unit – Clearance

- Evo EVent® arrives palletized & strapped in a heavy corrugated shipping carton. Once unpacked, it is important to have adequate clearance to move and position the unit in place. Allow minimum of 106.7cm (42") opening into the space or building to place unit inside. If not possible, unit can be rigged, lifted off its casters and rolled to its back side (Guest Side, see page 2). All loose components and large access panels removed to allow for smaller door clearances.
- If EVent® is installed into a cart or cabinet, the chef's side (touchscreen control, fire pull station, inlet aperture) should be facing out, accessible to cooking staff and unobstructed.

### Electrical Outlet & Fire Alarm Placement Clearances

- Unit is equipped with factory installed cord and plug. If final electrical connection is located on floor, the receptacle needs to be flush with the final floor finish to allow unit to roll easily over plug. If unit is hard wired, flexible conduit with adequate length will need to be installed to allow for housekeeping.
- If building fire alarm is required, the above considerations apply.

### Sneeze Guard Installation

- Allow a minimum 25.4mm (1") air space from counter to bottom of glass for creation of an "air curtain". 101.6mm (4") additional clearance from wall to unit if guest side is installed against wall.

### Ventilation Considerations

- The HVAC system plays a large part in the efficiency of the Evo EVent® unit. The HVAC system should be designed to allow adequate cooling load for the dining space, while minimizing the velocity of air exiting the diffusers.
- If velocity is unavoidable, diffusers should be positioned to direct air away from the Evo EVent® cooking surface. Air blowing across the cooking surface will inhibit the designed capture of smoke and grease laden vapor.
- A minimum of 0.033 cubic meter (m<sup>3</sup>/s) of fresh air per minute is required both in and out of cooking area to ensure the dilution of cooking aromas. Dedicated Make-up Air unit not required. Please consult your HVAC contractor.

### Acoustic Considerations – Dining Space

- Although Evo EVent® with its integrated ventilation system brings customers closer to the cooking experience by eliminating the need for noisy ventilation hoods, certain surfaces can reflect, rather than absorb ambient noise. If hard surface finishes (i.e. stone, glass) are used throughout the space, softer surfaces may need to be introduced to absorb reflecting sounds and noise.