

PFC SERIES MODELS

VENTLESS/HOODLESS COUNTERTOP DEEP FRYER

Advanced by Design



- SELF VENTING
- ODORLESS
- HEPA STYLE AIR FILTRATION
- INTEGRAL FIRE SUPPRESSION
- PROGRAMMABLE CONTROLS
- EASY TO CLEAN
- SMALL FOOTPRINT
- LARGE OUTPUT
- MODULAR DESIGN



PERFECT FRY COMPANY LLC
42 Allen Martin Drive
Essex Junction, VT 05452

GENERAL INFORMATION:
Phone: 1-802-658-6600
Fax: 1-802-864-0183
Email: profits@perfectfry.com
83718 Rev A (1/2020)

www.PerfectFry.com

The Benchmark in Ventless Deep Frying



CLEARANCES

CLEARANCES
1" all around and 0" on top.

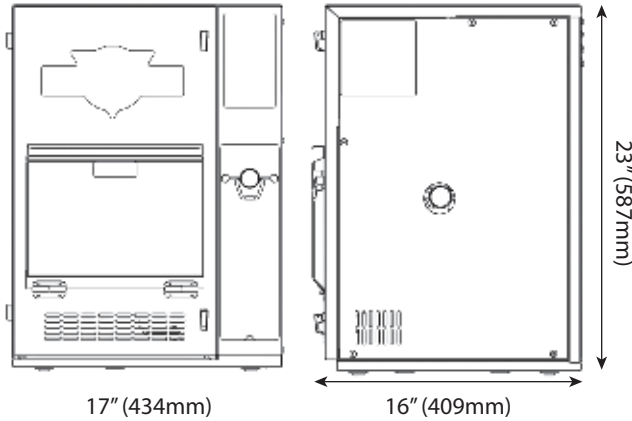

AIRFLOW DIAGRAM

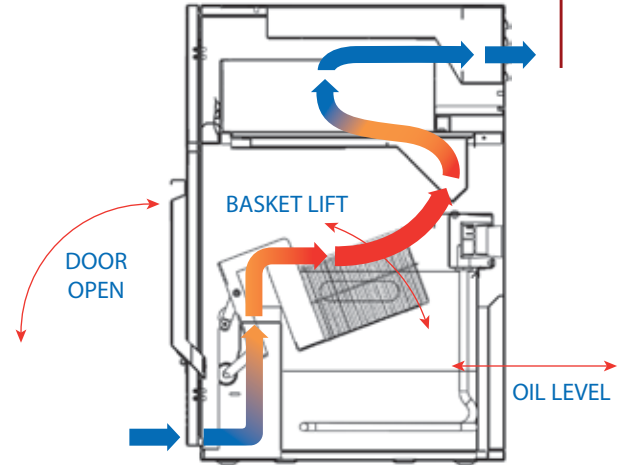

SPECIFICATIONS TABLE

MODEL*	PFC570	PFC375	PFC570	PFC187
ORDER NUMBER	Contact Customer Service, 603-225-6684			
POWER SUPPLY (volts)	240	240	208	120
CURRENT (amps)	24	16	27	16
CORD OPTION	8/3 Power Cord, NEMA 6-50 Plug	10/3 Power Cord, NEMA L6-30 Plug	8/3 Power Cord, NEMA 6-50 Plug	10/3 Power Cord, NEMA 5-20Plug
POWER (kilowatts)	5.7	3.8	5.7	1.9
CAPACITY (lbs/hr)**	60	45	60	30

BASKETS

OPTIONAL BASKET COVER
(ordered separately
part no. 6HT002)

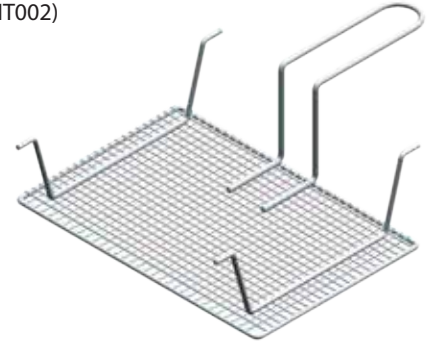

GENERAL SPECIFICATIONS

(All Models)

*International models available upon request.
**Using 1 1/2 minute fast fries.

Phase	Single (3 wire)
Cycles	50/60 Hz
Weight	80 lbs (36 kg)
Shipping Weight	95 lbs (43 kg)
Shipping Dimensions	Depth 22" (559 mm) Width 22" (559 mm) Height 27" (686 mm)
Shipping Cube	7.56 ft ³ (.214 m ³)
Oil Capacity	2 US Gallons (8 L)
Construction	304 Stainless Steel
***Locking Cabinet Option Also Available	

EXTRA LARGE
(32oz/6 servings)

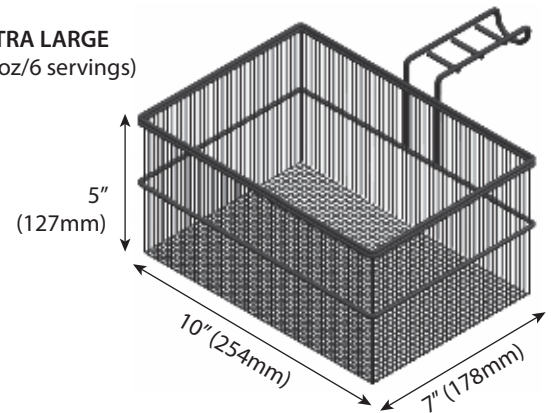

SPECIFICATIONS SUBJECT TO CHANGE WITHOUT NOTICE.

© 2020 Perfect Fry Company LLC. PRINTED IN USA.

83718 Rev A (1/2020)

